

MAGTROL

**MULTI-RANGE
DIGITAL
POWER ANALYZER
MODEL 4612B**

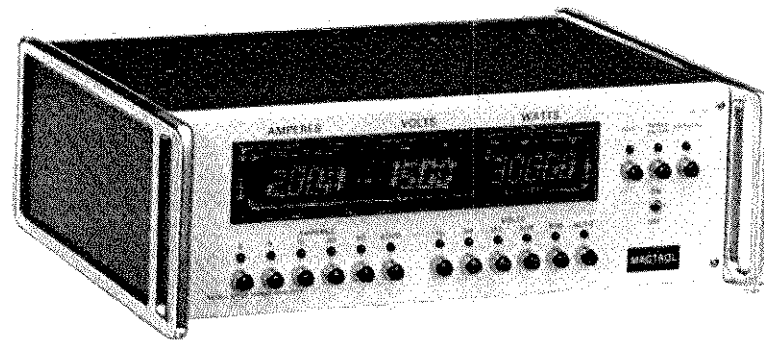

**INSTRUCTION
AND
REFERENCE
MANUAL**

Archived Manual

**This product is no longer in
production.**

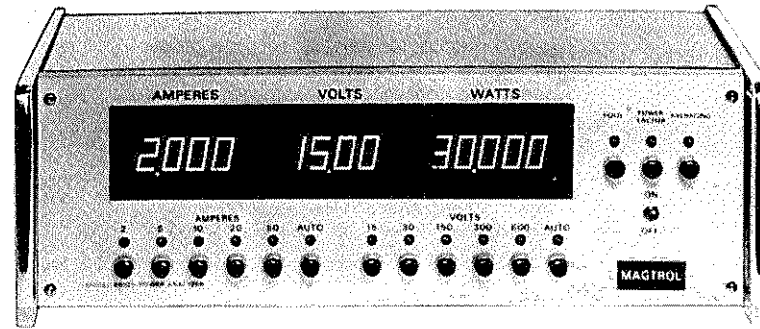

FRONT

UNIT IS 15" WIDE BY 12" DEEP BY 5" HIGH;
ADAPTERS AVAILABLE FOR 19" PANEL.

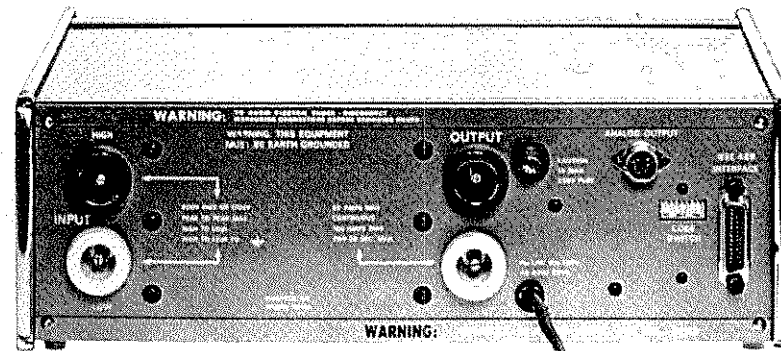

BACK

.....

.....

Table of Contents

SECTION 1

	Page
1.1 INTRODUCTION	3
1.1.1 UNPACKING	4
1.1.2 CHECK-OUT	4
1.1.3 RATINGS AND PRECAUTIONS	4
1.1.4 INDUCTIVE LOADS	5
1.2 CONNECTING THE 4612B	5
1.2.1 AC/DC LINE CONNECTIONS	5
1.2.2 TWO WATTMETER THREE PHASE	6
1.3 OPERATIONAL DESCRIPTION	6
1.3.1 "AMPERES" READOUT	6
1.3.2 "VOLTS" READOUT	7
1.3.3 "WATTS" READOUT	7
1.3.4 "POWER FACTOR" FUNCTION	7
1.3.5 "HOLD" FUNCTION	7
1.3.6 "AVERAGING" FUNCTION	7
1.3.7 AMPS RANGE INSTABILITY	8
1.4 ANALOG OUTPUT OPTION	8
1.5 CURRENT-POTENTIAL TRANSFORMER INSTALLATION	9
1.6 ACCURACY	9

SECTION 2

2.1 USING THE IEEE-488 (GPIB)	10
2.2 COMPUTER TYPES	11
2.2.1 HEWLETT-PACKARD	11
2.2.2 IBM PC™ AND COMPATIBLES	11
2.3 MODEL 4612B GPIB DATA OUTPUT	12
2.3.1 READ CYCLE	12
2.3.2 PROGRAMMING EXAMPLE : HP BASIC™	12
2.3.3 PROGRAMMING EXAMPLE : MS DOS, BASICA™	12
2.3.4 PROGRAMMING EXAMPLE : MS QUICK BASIC™	13
2.4 MODEL 4612B GPIB INSTRUCTIONS	14
2.4.1 CONTROL CHARACTERS	14
2.4.2 "HELP" INSTRUCTION	14
2.4.3 SPECIAL MEMORY ACCESS INSTRUCTIONS	14

SECTION 3

3.1 THEORY OF OPERATION	15
3.1.1 CURRENT AND VOLTAGE DETECTION	15
3.1.2 SIGNAL CONVERSION	15
3.2 CALIBRATION	16
3.2.1 VOLT-AMPS ACCURACY	17
3.2.2 WATTS CALIBRATION	17
3.2.3 PRECISION CALIBRATORS, USE OF	17
3.2.4 POWER FACTOR COMPLIANCE	18

™Registered trademark of International Business Machines Inc.

™Registered trademark of Hewlett-Packard Corp.

™Registered trademark of Microsoft Corporation



SECTION 1

1.1 INTRODUCTION

1.1.1 UNPACKING

The Model 4612B is adequately packaged for shipping. We recommend that all cartons and internal cushioning material be saved until the unit is checked out and normal operation is established. In the event of shipping damage, notify the carrier within 24 hours and have all the shipping material available for his inspection. Please call the Magtrol Customer Service Dept.

1.1.2 INSTRUMENT CHECK-OUT

Plug the LINE CORD into a standard power source. The rear panel is marked with the appropriate instrument power source, 117 or 230 volt, whichever was specified at the time of purchase. If unspecified, 117V 60 Hz is assumed for all domestic shipments.

THE LINE CORD ON THE POWER ANALYZER IS THE STANDARD (NATIONAL ELECTRICAL MANUFACTURERS ASSOCIATION) THREE-WIRE GROUNDED LINE CORD. THE LINE CORD MUST CONNECT TO AN EARTH-GROUNDED OUTLET. FAILURE TO MAINTAIN THE 4612B CABINET AT GROUND POTENTIAL COULD RESULT IN AN ELECTRICAL SHOCK HAZARD.

PLEASE NOTE: In all of the following, the term LED refers to the Light Emitting Diode red indicator on the front panel above it's respective pushbutton.

Turn the unit on.

The AMPERES, VOLTS and WATTS should read zero, or a very small value. The AMPERES RANGE LED's should indicate 2 and AUTO RANGE, the VOLTS RANGE LED's 15 and AUTO RANGE.

Select the 50 AMPERE RANGE.

An audible "hum" should be heard, the AUTO LED should extinguish, and the 50 AMP LED should go on.

Select the AUTO AMPERE RANGE.

The 2 AMP and AUTO LED's should go ON. The shunt control relay will open causing the "hum" to diminish.

If all of the above checks out, and the appearance is normal, assume satisfactory operation.

The 4612B must be operated in a nearly horizontal position.

1.1.3 MODEL 4612B RATINGS AND PRECAUTIONS

Before connecting the power source to be measured to the 4612B, please observe the following maximum instrument ratings and precautions.

VOLTAGE: Line to line, or line to ground — 1000 VRMS.

CURRENT: 50 Amperes maximum continuous, 100 amps not to exceed 10 seconds duration.

1.1.4 INDUCTIVE LOADS

WARNING—Inductive surges: If the voltage to either the line or load side exceeds 2000 VRMS, line to line or line to ground, damage to the 4612B could result. Upon opening a circuit without suppression, high voltage surges from motors, transformers and other inductive type loads may briefly attain potentials of many kilovolts.

If a circuit breaker is to be installed, it must be installed on the load side of the 4612B (downstream). This practice will leave the low impedance line always connected to the instrument for arc suppression.

If the line side must also contain a breaker, it is good practice to devise a circuit such that the input breaker cannot be opened until after the load side is opened. However, this may not protect the instrument against excessive LINE to GROUND potentials, in which event additional protection must be externally provided. Arc suppression devices such as metal oxide varistors (MOV's), installed line to ground, AT THE DEVICE UNDER TEST, are good. These devices will be available locally, or from Magtrol for your convenience. Contact customer service.

1.2 CONNECTING THE 4612B

Wire the input/output lines to the SUPER-CON™ female connectors provided. Install the connectors into the 4612B. Wiring should be neat and of adequate capacity to carry the expected load. Inadequate capacity wiring is not only dangerous, but line drops create reading errors. **WARNING: ALWAYS LEAVE THE OUTPUT SIDE CONNECTORS IN PLACE.** The male connector pins, although recessed, could present a shock hazard to probing fingers if the INPUT connectors and live power line are connected.

Please refer to the following connection diagram and observe the polarity with reference to the line ground side.

1.2.1 SINGLE PHASE AC/DC LINE CONNECTION

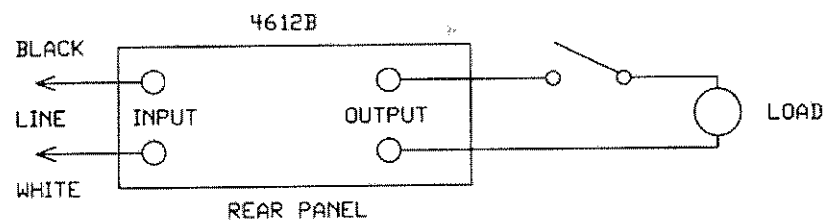

FIGURE 1

™ Registered trademark of Superior Electric Corp.

1
2
3
4
5
6
7
8
9
10
11
12
13
14
15
16
17
18
19
20
21
22
23
24
25
26
27
28
29
30
31
32
33
34
35
36
37
38
39
40
41
42
43
44
45
46
47
48
49
50
51
52
53
54
55
56
57
58
59
60
61
62
63
64
65
66
67
68
69
70
71
72
73
74
75
76
77
78
79
80
81
82
83
84
85
86
87
88
89
90
91
92
93
94
95
96
97
98
99
100

1.2.2 TWO WATTMETER THREE PHASE INSTALLATION

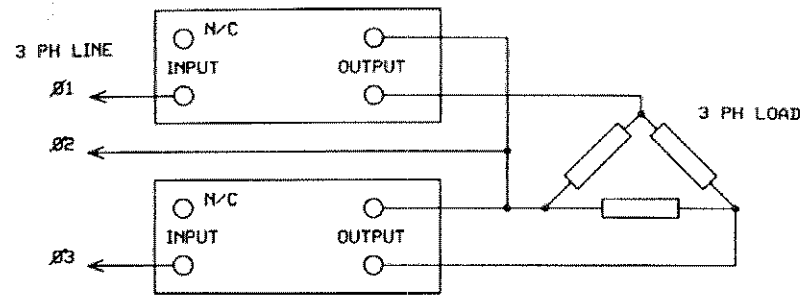

FIGURE 2

PLEASE NOTE: If the power factor is less than .5, the polarity on one wattmeter will change from plus to minus (through zero). Since the true WATTS is the algebraic sum of the two wattmeters, knowledge of the signs is necessary. If the Model 4612B's contain the ANALOG OUTPUT option, the watts (relative) polarity is available by reading both analog watts outputs. Where the power factor is greater than .5, the polarity of both wattmeters will always be equal and true power is simply the unsigned sum.

1.3 OPERATIONAL DESCRIPTION

With a power source and load applied, readings of amps-volts-watts will be observed. There are three MODE pushbuttons, ten RANGE pushbuttons and two AUTO range pushbuttons. All have adjacent LED's to indicate range and mode selection.

1.3.1 "AMPERES" RANGING AND READOUT:

The AMPS readout is four digits, floating point, displaying the current measured between the white INPUT and OUTPUT connectors on the rear panel. The indication is true RMS from DC to over 2 KHz.

When the 4612B is first turned on, the default operation is AUTO ranging. Up-ranging occurs if the RMS value of current exceeds the full scale range plus approximately 20%, or if a peak value exceeds the full scale RMS value $\times 1.414$ plus 20%.

Down-ranging occurs when the level is equal to just less than the full scale value of the next lower range.

Selection of any range pushbutton causes the autoranging function to partially disable. The autoranging function will always override a manual selection in the event the level of current exceeds the selected range as stated above thus preventing erroneous readings and possible overheating of the internal shunts. If the amps value decreases, the range originally selected will return and that range will remain fixed. To resume autorange operation, depress the AUTO pushbutton.

1.3.2 "VOLTAGE" RANGING AND READOUT:

The VOLTS reading is also four digits, floating point, displaying the true RMS voltage between the WHITE and BLACK LOAD (output) terminals.

The automatic and manual range selection is identical to that described under AMPS above.

1.3.3 "WATTS" READOUT:

This readout has two modes of operation, WATTS or POWER FACTOR, selected by the respective pushbutton. The readout is five digits, floating point, with ranging from milliwatts through 30 KW. A more technical description is provided in SECTION 3.

In WATTS mode the reading is equivalent to: $W = EI \cos \theta$

1.3.4 "POWER FACTOR" READOUT:

Selecting this mode of operation results in the WATTS reading being substituted with a power factor calculation.

The POWER FACTOR reading is: $PF = \frac{EI \cos \theta}{VA}$

1.3.5 "HOLD" FUNCTION

The HOLD pushbutton may be depressed at any time. All internal machine functions are halted except the autoranging. In the AVERAGING mode the process is halted and the last running average value is latched onto the displays. There is a special use for the HOLD in combination with the AVERAGING function described as below.

1.3.6 "AVERAGING" FUNCTION

Averaging is an integration function and continues regardless of range changes. The displays update normally, reporting the running integrated value which is equal to the average amps-volts-watts over the accumulated period of time that the 4612B was in that mode. The maximum averaging time period is in excess of one year.

If a slowly changing value of either the line, load or frequency make the readout variation difficult to follow, the averaging function will accurately stabilize the reading. It may require anywhere from several seconds to several minutes depending upon the rate and magnitude of change.

Additionally, the data stored in the averaging registers (the summation of amps, volts, watts and the summation count) is maintained when the AVERAGING is disabled. It is non-volatile, meaning that if the 4612B is turned off, the data is still retained indefinitely.

To maximize the usefulness of this feature please understand the following: The AVERAGING and HOLD functions work together. Normal operation occurs when entering the AVERAGING mode with the HOLD 'OFF'. All internal data registers are first cleared and the averaging starts fresh.

However, if the AVERAGING is ENABLED when the HOLD is 'ON', the memory is not cleared. The HOLD automatically releases and immediate data is then averaged into the previously retained data, regardless of how long ago that data was accumulated.

This permits the measurement of the true integrated power consumption on complex types of loads or data requirements, such as those where power is applied only intermittently, or where a combination of devices require integrated measurements, with interruptions in between.

Power factor will be averaged if the AVERAGING is initiated while in the POWER FACTOR mode. The 4612B will accept a change from POWER FACTOR to WATTS, but not the other way around, while averaging.

1.3.7 AMPS RANGE INSTABILITY

If a high crest factor (distorted wave shape) voltage or current is of sufficient duration or magnitude to create a significant reading error, the 4612B will uprange. However, if the true RMS value should be less than the full scale level of the next lowest range, the 4612B's microprocessor receives conflicting signals; the overload detection saying "uprange" while the true RMS value says "downrange". The system will respond by alternately switching between the two ranges. If this occurs, it will be necessary to manually (or GPIB), select the upper range—disabling the autoranging mode.

1.4 ANALOG OUTPUT OPTION

This option provides analog outputs for AMPS, VOLTS and WATTS.

There are four lines, isolated from the measuring circuits. The outputs are installed on a standard 5 pin DIN connector mounted on the rear panel of the 4612B. Pin-out is shown in FIGURE 3. The analog signals are proportional to the AMPS, VOLTS and WATTS ranging from a few millivolts to a full scale value of 7 volts for each range. The ripple content is less than 50 millivolts for all frequencies above 60 Hz. The operational amplifier type outputs are low impedance with a maximum drive current of 4.0 milliamperes. All are referenced to an isolated common line.

There is no analog output for power factor.

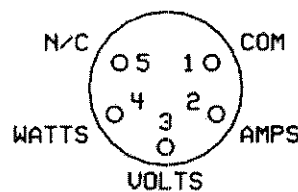

FIGURE 3

1.5 CURRENT/POTENTIAL TRANSFORMER INSTALLATION

Figure 4 schematic shows a typical connection method for both a current transformer (CT) and a potential transformer (PT). It is important to understand that the 4612B requires the White LOAD (output) terminal as the common to both current and potential measuring circuits.

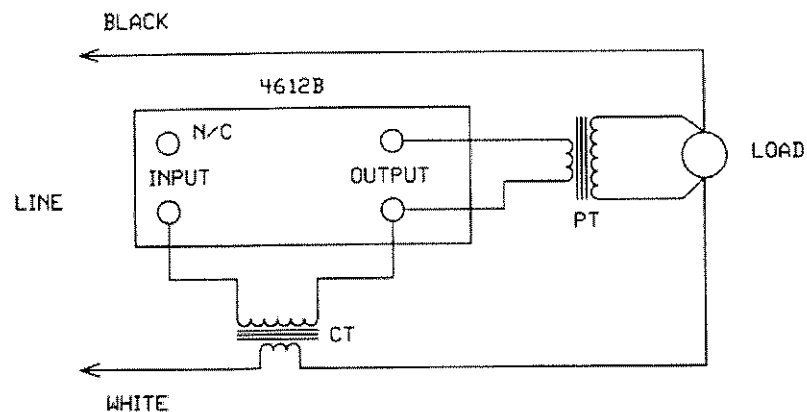

FIGURE 4

1.6 ACCURACY:

Conditions:

Between 1% and 120% of full scale range.

Frequency DC to 1.0 KHZ

Crest factor <10:1. Power factor .1 to 1.0, lead or lag.

Ambient temperature 72°F ± 10°F.

VOLTS = reading ± (.2% of reading + .20% range)

AMPS = reading ± (.22% of reading + .25% range)

WATTS = reading ± (.2% of reading + .3% VA range)

PF = reading ± (VA error ± W error)

Temperature coefficient: <.01%/°C (.003 typical).

All instruments are shipped with an Accuracy Certification from Magtrol Inc., traceable to the NBS, and so stated.

Magtrol is a member of the American National Standards Institute. Calibration practice and accuracy statements are based upon ANSI certification C39.6 and other standards.



SECTION 2

2.1 USING THE IEEE-488 (GPIB)

The IEEE-488 or GPIB (General Purpose Interface Bus) permits direct connection of the 4612B to any computer, so equipped, for the purpose of data acquisition and instrument control.

On the rear panel of the 4612B there is a small rectangular opening on the upper right side, providing access to a miniature eight position slide switch. The primary address of the 4612B is set here. The default (factory) setting of this switch is 12. If this address is suitable, no alteration of the setting is necessary. If a different setting is required please refer to the following chart for the set-up.

SWITCH SEGMENT					ADDRESS
1	2	3	4	5	
LSB				MSB	
0	0	0	0	0	0
1	0	0	0	0	1
0	1	0	0	0	2
1	1	0	0	0	3
0	0	1	0	0	4
1	0	1	0	0	5
0	1	1	0	0	6
1	1	1	0	0	7
0	0	0	1	0	8
1	0	0	1	0	9
0	1	0	1	0	10
1	1	0	1	0	11
0	0	1	1	0	12
1	0	1	1	0	13
0	1	1	1	0	14
1	1	1	1	0	15
0	0	0	0	1	16
1	0	0	0	1	17
0	1	0	0	1	18
1	1	0	0	1	19
0	0	1	0	1	20
1	0	1	0	1	21
0	1	1	0	1	22
1	1	1	0	1	23
0	0	0	1	1	24
1	0	0	1	1	25
0	1	0	1	1	26
1	1	0	1	1	27
0	0	1	1	1	28
1	0	1	1	1	29
0	1	1	1	1	30
1	1	1	1	1	31

BINARY WEIGHT:
1 2 4 8 16

1	2	3	4	5	6	7	8
---	---	---	---	---	---	---	---

1
0

NOT USED ↑↑↑

NOTE: A change in the primary address will affect that value in the following software examples.

2.2 COMPUTER TYPES

2.2.1 HEWLETT-PACKARD

Most Hewlett-Packard lab computers, equipped with the GPIB interface, contain the GPIB driver routines in the operating system. All that is necessary is to write the commands using the correct port and primary address identification. If this is the case, proceed to paragraph 2.3.

2.2.2 IBM PC, COMPATIBLES, OR OTHER

If any of the numerous PC's are to be used, an IEEE-488 interface hardware card with suitable software is required. For recommendations and assistance in setting up a interface for an IBM PC, or compatible, please request Magtrol software assistance.

Communication termination characters are a common problem with PC interfaces to any GPIB controlled instrument. The 4612B is configured for the Hewlett-Packard standard termination characters of CARRIAGE RETURN (CR hex OD) and LINE FEED (LF hex OA). On a read cycle (4612B to computer), the 4612B expects the standard IEEE-488 read protocols and primary address. It responds with a data string followed by CR and LF. This signals the end of transmission. Upon receipt of these characters, the computer must be configured to terminate GPIB communication and proceed with its own program execution. On a write cycle (computer to 4612B), the 4612B expects to receive (1) the primary address, (2) instructional data string, (3) the termination characters of CR and LF. If these terminators are not forthcoming, the 4612B has no way of knowing when to terminate handshaking, reset the GPIB and continue with its program loop. If omitted, the only way to restore operation is to turn the unit off, then on again, or force a GPIB interface reset — if available.

2.3 MODEL 4612B GPIB DATA OUTPUT

2.3.1 READ CYCLE

In a read (4612B to computer) command mode, the 4612B will output a data string containing the information on the AMPS-VOLTS-WATTS read out. This is output in ASCII format as follows:

```
A=aa.aaV=vvv.vW=ww.www<cr><lf>
```

Where: aa.aa is the amperes value exactly as displayed on the AMPERES four digit readout, vvv.v for VOLTS and ww.www is the five digit WATTS readout. The string length is always 24 characters. Most PC's will require that the input string length be dimensioned. Most HP computers will ignore any characters beyond the default (usually 18) unless the input variable is dimensioned.

If the operating mode is PF instead of WATTS, the "W" changes to "P".

2.3.2 PROGRAMMING EXAMPLES IN HP BASIC

The following example is for the purpose of demonstrating how data is transmitted from the 4612B to the host computer.

```
10 DIM A$(24)      'Length of data string + CR + LF
20 CLEAR           'Clear the screen
30 ENTER 712; A$   '7=PORT, 12=GPIB address, A$=input var.
40 DISP A$        'Place on CRT.
50 GOTO 30        'Keep running.
```

NOTE: Check individual computer manual for proper GPIB PORT number.

Programming example in HP BASIC to command the 4612B go to a fixed range, then return data:

```
10 DIM A$(24)      'Length of variable
20 OUTPUT 712; "A10" '7=PORT, 12=GPIB address, set 10 AMPS range
25 WAIT 100        'Give it .1 sec to update
30 ENTER 712; A$   'Fetch data.
40 DISP A$        'Place on CRT.
50 GOTO 30        'Keep running.
```

2.3.3 PROGRAMMING EXAMPLE FOR MS DOS USING BASICA

Various GPIB interfaces are available for IBM PC's and compatibles. The following program is applicable for National Instruments Inc., Part number GPIB-PC2A, hardware interface and software installation.

This example assumes that the National software has been loaded and configured with the correct termination operators of CR and LF. (Explanation in paragraph 2.1.2)

The following example will transmit an instruction to configure the instrument to set 150 volt range, then input the data.

In the following program, lines 1 thru 6 are for assembly language subroutines.

```
1 CLEAR, 60304!      'Declarations
2 IBINIT1 = 60304!
3 IBINIT2 = IBINIT1 + 3
4 BLOAD "BIB.M", IBINIT1
5 CALL IBINIT1 (IBFIND, IBTRG, IBCLR, IBPCT, IBSIC, IBLOC, IBPPC, IBBNA,
IBONL, IBRSC, IBSRE, IBRSV, IBSAD, IBIST, IBDMA, IBEOS, IBTMO, IBEOT,
IBRDF, IBWRTF)
6 CALL IBINIT2 (IBGTS, IBCAC, IBWAIT, IBPOKE, IBWRT, IBWRTA, IBCMD,
IBCMDA, IBRD, IBRDA, IBSTOP, IBRPP, IBRSP, IBDIAG, IBXTRC, IBRDI, IBW-
RTI, IBRDIA, IBWRTIA, IBSTA%, IBERR%, IBCNT%)
10 CLS
20 BDNAMES$="DEV12"      'Primary address of 4612B.
30 WRT$="V150"+CHR$(13)+CHR$(10)  'Instruction for 150 Volt range
                                + CR + LF.
40 RD$=SPACES$(24)      'Dim the input statement + CR + LF.
50 CALL IBFIND (BDNAMES$, BD%)  'Return a unit descriptor.
60 CALL IBWRT (BD%, WRT$)      'Set 150 volt range.
70 CALL IBRD (BD%, RD$)      'Fetch the data.
80 PRINT RD$              'Display on CRT.
90 GOTO 70                'Continue inputting.
100 End
```

2.3.4 PROGRAMMING EXAMPLE IN MICROSOFT QUICK BASIC

The software requirements for "QB" in conjunction with the National Instruments Inc., Part number GPIB-PC2A, do not require lines 1 thru 6 above.

The following program initiates the AVERAGING mode of operation, then displays the data, identifying each parameter.

```
WRT$="1"+CHR$(13)+CHR$(10)  'Instruction for AVERAGING + CR + LF.
RD$=SPACES$(24)            'Dim the input statement + CR + LF.
BDNAMES$="DEV12"           'Primary address of 4612B.
CALL IBFIND (BDNAMES$,BD%) 'Return a unit descriptor.
CALL IBWRT (BD%,WRT$)     'Set AVERAGING mode.
AGAIN: CALL IBRD (BD%,RD$) 'Fetch data.
      A$=MID$(RD$,3,5)     'Pull out amps value.
      V$=MID$(RD$,10,5)   'Pull out volts value.
      W$=MID$(RD$,17,6)   'Pull out watts value.
      CLS: PRINT "Average: Volts=";V$;" Amps=";A$;" Watts=";W$
      GOTO AGAIN
END
```

1 2 3 4 5 6 7 8 9 10 11 12 13 14 15 16 17 18 19 20 21 22 23 24 25 26 27 28 29 30 31 32 33 34 35 36 37 38 39 40 41 42 43 44 45 46 47 48 49 50 51 52 53 54 55 56 57 58 59 60 61 62 63 64 65 66 67 68 69 70 71 72 73 74 75 76 77 78 79 80 81 82 83 84 85 86 87 88 89 90 91 92 93 94 95 96 97 98 99 100

2.4 MODEL 4612B GPIB INSTRUCTION SET:

2.4.1 MODEL 4612B CONTROL CHARACTERS

The 4612B recognizes the following characters as the instruction set for machine control, resulting in the actions described.

DATA STRING	ACTION
AA	Set Amps autoranging ON.
A2	Set Amps range to 2, AUTO off.
A5	Set Amps range to 5, AUTO off.
A10	Set Amps range to 10, AUTO off.
A20	Set Amps range to 20, AUTO off.
A50	Set Amps range to 50, AUTO off.
H	Sets the HOLD function ON.
HC	Sets the HOLD function OFF. (Clear)
I	Sets the AVERAGING function ON.
IC	Sets the AVERAGING function OFF.
L	Locks out all front panel controls.
LC	Restores normal front panel control.
P	Sets the Watts display to read Power Factor.
VA	Set Volts autoranging ON.
V15	Set Volts range to 15, AUTO off.
V30	Set Volts range to 30, AUTO off.
V150	Set Volts range to 150, AUTO off.
V300	Set Volts range to 300, AUTO off.
V600	Set Volts range to 600, AUTO off.
W	Sets the Power Factor display to read Watts.

2.4.2 "HELP" OUTPUT INSTRUCTION

The 4612B recognizes this character string as a special event. After "HELP" is written to the 4612B, upon the next GPIB read instruction (4612B to computer), the above instruction character set is transmitted instead of amps-volts-watts data. The output is organized for an 80 column by 23 line screen format. The computer input variable must be dimensioned for 1842 character length string ($80 \times 23 + CR,LF = 1842$)

Upon completion, the 4612B automatically resets to normal operation and subsequent read instructions will return the normal amps-volts-watts data.

2.4.3 SPECIAL 4612B MEMORY ACCESS

Data contained in all of the memory elements of the 4612B is available for access through the GPIB. For example, if for some reason the averaging summation count were desired, the following procedure would return that value: Output to the 4612B—"M2086208A". Upon the next read cycle the 4612B will return the data contained between addresses (HEX) 2086 and 208A, inclusive, which happens to be 10 digits (packed BCD) equal to the averaging summation count. By this method, the entire operating system object code and all variables are available. The system memory map would be required, therefore, for more specific information please contact Magtrol software support.

An additional instruction available is the string "AZ". This results in the auto-zero process being temporarily deleted, useful during the calibration and balancing procedures in the following section. When the 4612B is turned OFF, then ON, the autozeroing process automatically restores.

.....

.....



SECTION 3

3.1 THEORY OF OPERATION

3.1.1 CURRENT AND VOLTAGE DETECTION

The Model 4612B does not utilize current or potential transformers at the input circuits. Figure 5 shows the actual circuit configuration that the 4612B presents to the line and load for the purpose of measuring power.

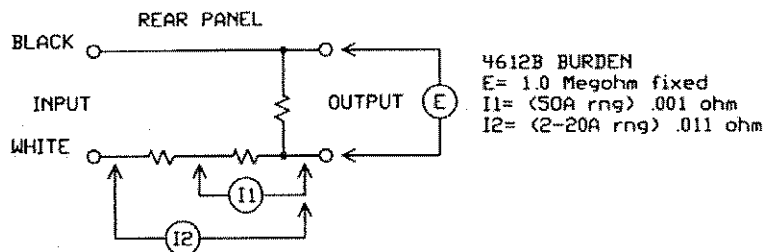

FIGURE 5

3.1.2 SIGNAL CONVERSION

The signal voltages at 'E' and 'I' on Figure 5 are applied to operational amplifiers for signal processing. This provides a true-value input capability without modifying the wave shape. It is the only accurate method for measuring true power and RMS equivalent of non-sinusoidal wave shapes, especially if there are DC insertions.

Referring to Figure 6, the amplifier outputs V and A are applied to two inputs each. These are a true RMS converter and X or Y inputs of a four quadrant analog multiplication element. The signal output of the multiplier is the instantaneous signed product of EI. This passes to a 2 pole Butterworth filter producing an average value, which is now $EI \cos \theta$.

The outputs of the converters are the true RMS values of volts, amps and watts.

The outputs of the RMS converters and the (watts) filter connect to precision voltage to frequency converters. The E, I and P values now pass through 2500 volt optical isolators to isolate the data from the line.

From this point the information is processed digitally under the control of an 8 bit microcomputer.

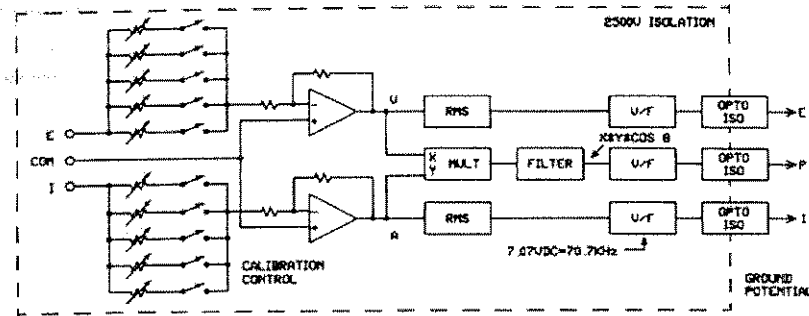

FIGURE 6

WARNING: Do not attach test instruments to the circuits or adjust any of the offset or balance potentiometers with any LINE POWER CONNECTED to the unit. Failure to observe this warning could result in serious personal injury, destruction of equipment and possible fire.

Complete schematic diagrams of the digital system are available from Magtrol and will be supplied upon request. As a general rule, field trouble-shooting of microprocessor systems is rarely effective without specialized equipment. Please contact customer service at Magtrol for assistance.

3.2 CALIBRATION

Re-calibration procedure for the Model 4612B is complex. However determining the accuracy of the 4612B readout is not. A procedure to periodically review the reading accuracy is good practice.

Until a calibration record is established, dependent upon the level of accuracy required, Magtrol recommends an initial accuracy check at approximately 90 days. This should be followed by verification at least once every 6 months, until a level of confidence and stability history is established. As with all instruments, accuracy stability is somewhat dependent upon extent of use, handling and environmental conditions. A simple verification of one commonly used range will establish a first order accuracy check of the instrument accuracy.

A source of undistorted and regulated AC power is required. If the power source is of known good sinusoidal quality, most any precision AC voltmeter and ammeter of at least .05% accuracy and resolution is satisfactory. Otherwise only thermal transfer standards for true RMS should be used. The necessity for using known high quality standards cannot be over-emphasized.

Due to common mode line considerations mentioned in the warning above, plus offset and balancing requirements, calibration adjustments should not be attempted without consulting the Instrument Calibration Dept. at Magtrol for assistance.

3.2.1 VOLT-AMPS ACCURACY CHECK

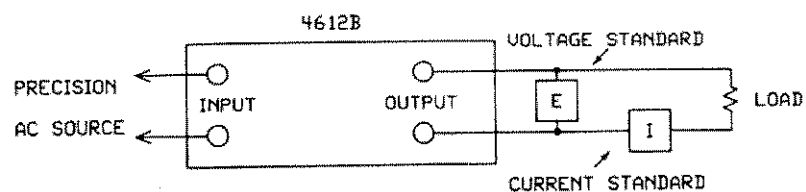

FIGURE 7

Connect the unit as shown. Compare the 4612B readings of volts and amps to the standards. This should be done at or near full scale on the range(s) of interest.

If a precision meter calibrator of at least the accuracies stated above is available, the above tests can be performed without the load as shown.

This will be applicable to volt-amps only. Refer to paragraph 3.2.3 for an explanation.

3.2.2 WATTS CALIBRATION

The easiest method for determining the accuracy of the power readout is to first establish the volts and amps calibration accuracy at or close to full scale on any volt and amp range. A near unity power factor load of (non-inductive) resistors or incandescent lamps is useful for this. Check that the watts reading is equal to the product of volt \times amps. Referring to Figure 6, please note that the same calibration controls which adjust the volts and the amps also calibrate watts. This means that a single point on only one range is required to establish watts accuracy, as it relates to the volt-amp readings. If another watts standard is to be used, be sure to compensate for any potential-shunt field burdens, since one of the wattmeters must handle the load of the second.

3.2.3 PRECISION CALIBRATORS FOR WATTS

IMPORTANT: Generally, precision instrument calibrators which supply a source of both voltage and current will not calibrate the 4612B watts measurement accurately. The difficulty relates to the inability to maintain the correct phase relationship between the voltage and current circuits. Typically, these instruments utilize a very low impedance source for current in order to minimize internal power dissipation.

Perhaps the problem is best described by considering the impedance triangle relating phase shift to inductance and resistance. On the 4612B, the current measurement circuit enters the rear panel, made of cold rolled steel, passes through the current sampling shunts and back out of the panel to the load. This is equal to one "turn" around an iron "core" resulting in some inductance inserted into the current circuit. In normal use it is of no consequence since current in a series circuit is the same throughout and the potential measurement is made "down stream", across the load, after this relatively small inductive insertion. Additionally, in actual use the 4612B is before a power absorbing load which will have a relatively high impedance.

1 2 3 4 5 6 7 8 9 10 11 12 13 14 15 16 17 18 19 20 21 22 23 24 25 26 27 28 29 30 31 32 33 34 35 36 37 38 39 40 41 42 43 44 45 46 47 48 49 50 51 52 53 54 55 56 57 58 59 60 61 62 63 64 65 66 67 68 69 70 71 72 73 74 75 76 77 78 79 80 81 82 83 84 85 86 87 88 89 90 91 92 93 94 95 96 97 98 99 100

With an AC current calibrator the major circuit resistance is the 4612B shunts plus the associated wiring involved. Therefore, the major elements of the standard impedance formula are an "R" which is very low and an "L" which is a few microhenries. The following is given as an approximation only, to demonstrate this effect.

Let L = 10 microhenries. (a reasonable value)

Let R (.011 Ohms (shunt Res) + .01 Ohms in wires etc.) = .02 Ohms.

Thus, $2 \pi fL$ = approximately .004 at 60 Hz.

Then:

$$\theta = \text{Arctan} \frac{2 \pi fL}{R} \qquad \theta = \text{Arctan} \frac{.004}{.02}$$

Therefore, θ will equal approximately 11 degrees, or a minimum 1.5% measurement error!

This is a procedural type error and not strictly a calibrator or 4612B error as such.

If the calibrator contains phase adjustment control, this will be useful only if it is infinitely adjustable (potentiometer means). It may be used to peak the power reading of the 4612B only. An alternative would be to measure the phase angle with another precision instrument. This must be done inside the 4612B rear panel with the probes connected across the active shunt and at the potential measurement points, exactly as the 4612B sees the true load power in its normal operation. Again, please refer to the WARNING above. Calibrator isolation from the live power line must be maintained.

3.2.4 4612B INTRINSIC POWER FACTOR COMPLIANCE.

If a check for phasing accuracy is required, the easiest method is to apply power to a very low power factor type load, connected as shown in Figure 1. A high capacity (several microfarad) "high Q" oil type capacitor with heavy gauge wiring, as a load, is an excellent method to establish the 4612B phase angle (power factor) accuracy. This type of load will draw current typically 89.5 degrees to just less than 90 degrees phase angle relationship to voltage. This should produce a very small wattage reading at a substantial volt-amp reading. It is easy to establish the phase accuracy of the 4612B to within a few minutes of arc up to approximately 1 KHz. by this method. Actual values of all parameters are easily calculated.

Phase accuracy is not subject to either long or short term drift in the 4612B.

1
2
3
4
5
6
7
8
9
10
11
12
13
14
15
16
17
18
19
20
21
22
23
24
25
26
27
28
29
30
31
32
33
34
35
36
37
38
39
40
41
42
43
44
45
46
47
48
49
50
51
52
53
54
55
56
57
58
59
60
61
62
63
64
65
66
67
68
69
70
71
72
73
74
75
76
77
78
79
80
81
82
83
84
85
86
87
88
89
90
91
92
93
94
95
96
97
98
99
100

1
2
3
4
5
6
7
8
9
10
11
12
13
14
15
16
17
18
19
20
21
22
23
24
25
26
27
28
29
30
31
32
33
34
35
36
37
38
39
40
41
42
43
44
45
46
47
48
49
50
51
52
53
54
55
56
57
58
59
60
61
62
63
64
65
66
67
68
69
70
71
72
73
74
75
76
77
78
79
80
81
82
83
84
85
86
87
88
89
90
91
92
93
94
95
96
97
98
99
100

MAGTROL LIMITED WARRANTY

This Magtrol product is warranted against defects in materials and workmanship for ninety (90) days from the date of delivery. We will repair or replace products which prove to be defective during the warranty period provided they are returned to Magtrol. Additionally, any repairs which may become necessary beyond the ninety (90) day warranty period will be made subject to review by our quality control department. No other warranty is expressed or implied. We are not liable for consequential damages.

Customer assistance agreements are available for Magtrol products that require maintenance and repair on site.

MAGTROL, INC.

BUFFALO, NEW YORK 14224

